

DATE:	PROJECT:	TYPE:
-------	----------	-------

Cut Point

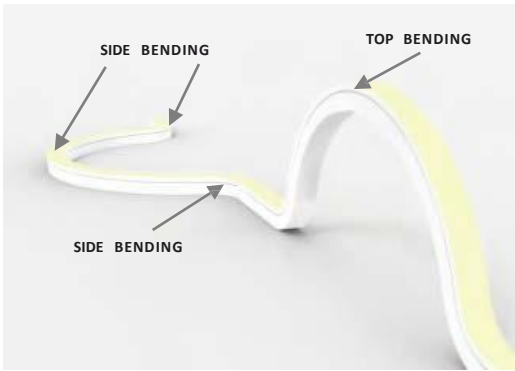

Features

- 3D Neon Flex (High light efficiency), IP67 silicone extrusión.
- 24V – (Power supply by other)
- 220 Lumens per foot at 3000K
- Dot-free and perfectly homogeneous linear LED light.
- 10mm x 10mm / 0.4" x 4" (W x H) (.5mm).
- Vertical and horizontal bending with bending diameter over 120mm (Vertical) and over 200mm (Horizontal).

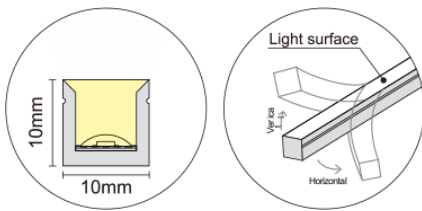

3D Bending Vertical Bending & Horizontal Bending

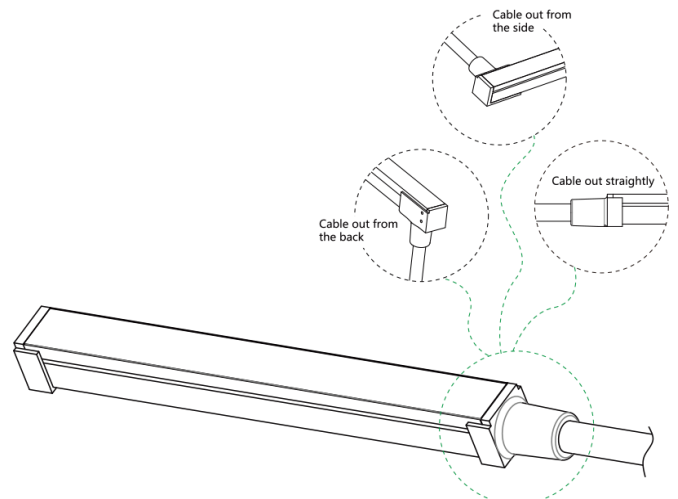

Ordering Code: EX: **SL-3DNN - 27K - 200 - 2.5W - IP67**

1
2
3
4
5

1. MODEL	2. COLOR TEMP	3. LM / FT	4. WATTAGE / FT	5. RATING
SL-3DNN	27K • 2700K	200LM/FT	2.5W	IP67
	30K • 3000K	220LM/FT		
	35K • 3500K	240LM/FT		
	40K • 4000K	250LM/FT		
	DTW • Dim-to-warm 2200k-3000k			

SPECIFICATIONS SUBJECT TO CHANGE, CONSULT FACTORY WHEN CRITICAL.

DATE:	PROJECT:	TYPE:
-------	----------	-------

Mounting Accessories



SL-3DNNAP
Aluminum Profile



SL-3DNNB
Buckle



SL-3DNNSC
Snake Channel

Cutting Accessories



SL-3DNNEP
End Cap



SL-3DNNES
End-Straight

Vertical Bending

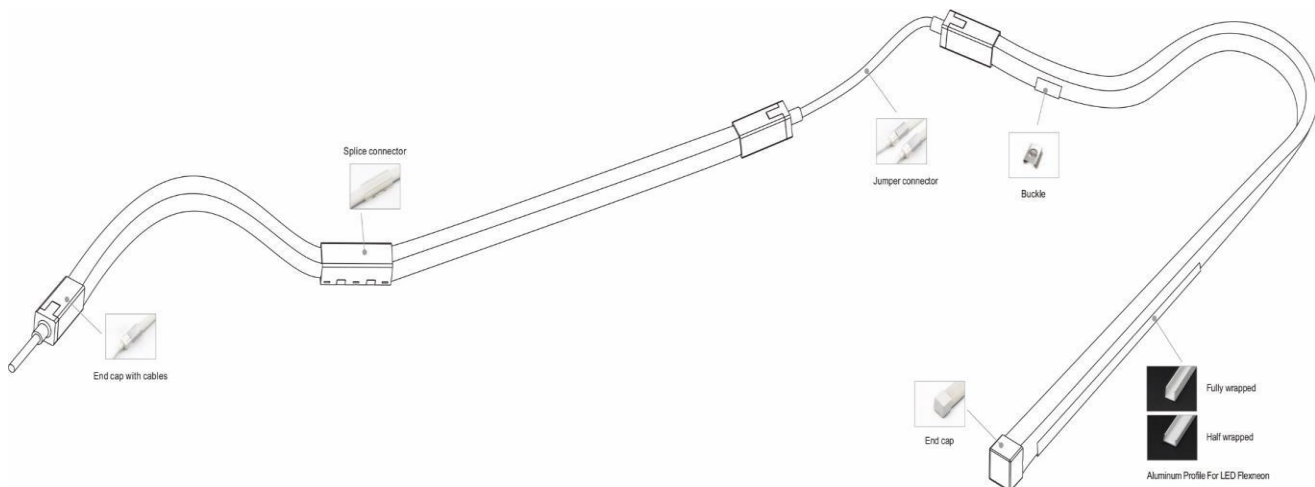

Features

- Uniform, dot-free, smooth and comfortable luminary.
- Vertical bending (Top view) flexible neon, can be bent vertically.
- IP67 waterproof with matt coated, anti dust.
- With multiple cutting accessories and matched mounting accessories.
- Consistent brightness without any decay.
- Dimmable with suitable contro system.
- UL approved.