

Read Instruction manual carefully to ensure proper installation.
Please keep this instruction manual for future using!

⚠ WARNING

To avoid the risk of fire, or electric shock this product should be installed, inspected, and maintained by a qualified electrician only. Installation should be completely by an individual familiar with the construction and operation of the luminaire. Installation of luminaire must be in accordance with nation and local building and electrical codes.

Safety Warning:

- To avoid electric shock:
Be certain electrical power is OFF before and during installation and maintenance.
Luminaire must be supplied by a wiring system with an equipment grounding conductor.
- To avoid burning hands:
Make sure lens and housing are cool when performing maintenance.
- To avoid product degradation:
Make sure the wire supply voltage is the same as the luminaire supply
Use proper supply wiring as specified on the luminaire nameplate.
Avoid use in environments containing sulfur, chlorine, or other halides, methyl acetate or ethyl acetate, cyanoacrylates, glycol ethers, formaldehyde or butadiene.

Notes:

- Instructions do not cover all details and all possible product configurations.
- Do not restrict luminaire ventilation.
- Ensure LED luminaire is not covered with material that will prevent convection or conduction cooling.
- Ensure LED luminaire has the correct polarity before installation
- Avoid exposing wiring to metal edges and sharp objects.

Maintenance:

Perform visual, electrical, and mechanical inspections on a regular basis. The environment and frequency of use should determine this. However, it is recommended that checks be made at least once a year. Electrically check to make sure that all connections are clean and tight. Mechanically check that all parts are properly assembled.

Installation Dimension (suspended)

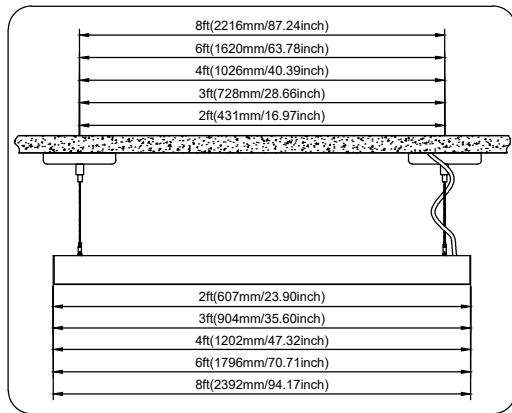

Surface mounted

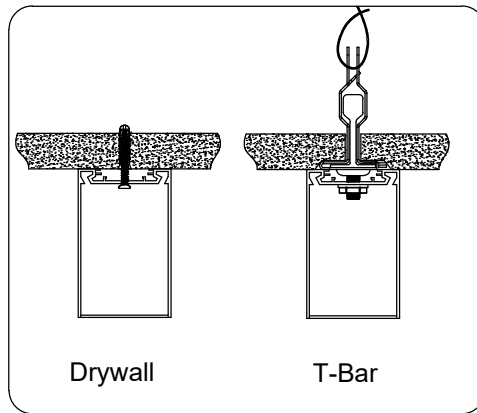

Dip switch for CCT

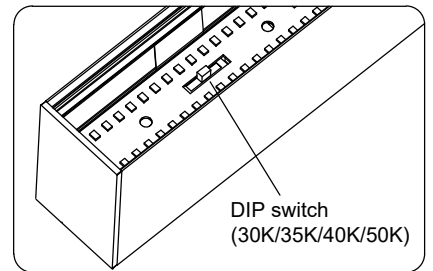

Wiring Diagram

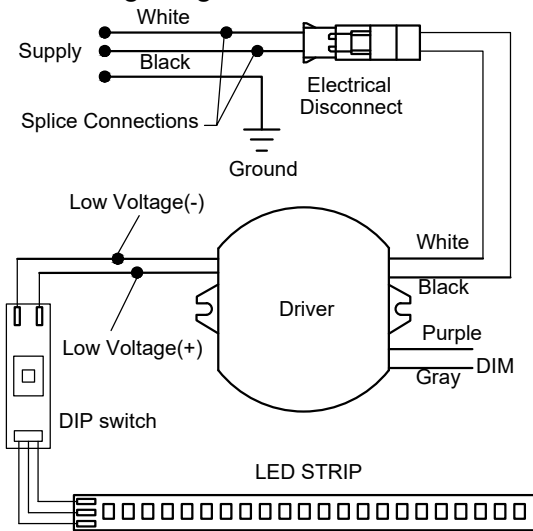

SUSPENDED MOUNT

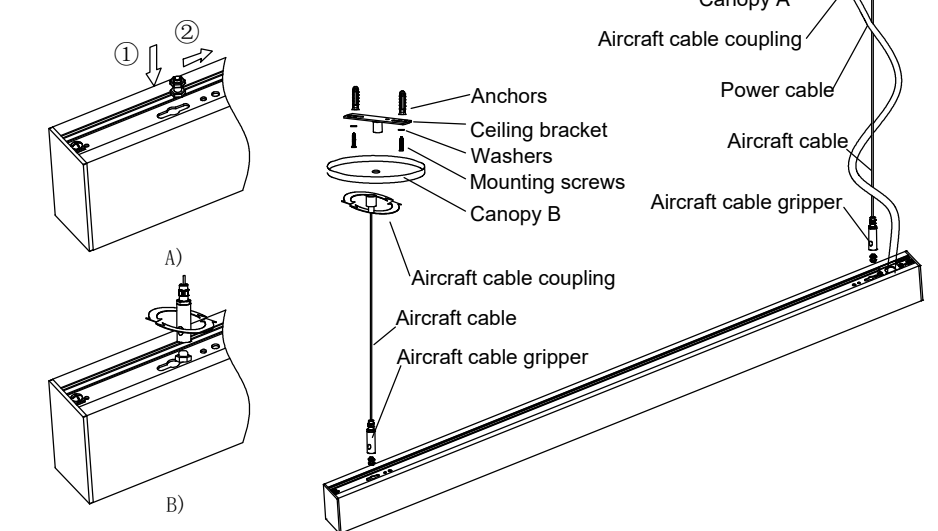

SUSPENDED MOUNT (UP & DOWN LIGHTING VERSION)

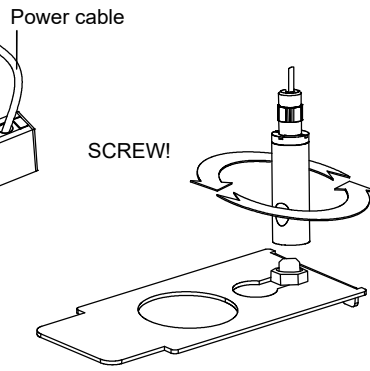
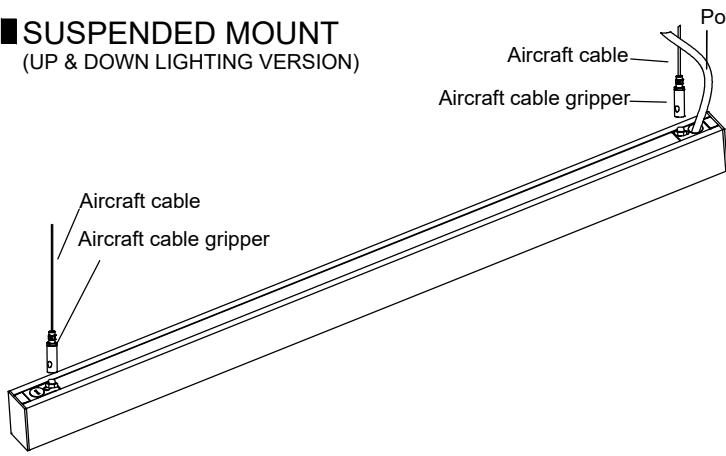

Installation Dimension	
2ft	482mm/18.98inch
3ft	779mm/30.67inch
4ft	1077mm/42.40inch
6ft	1671mm/65.79inch
8ft	2265mm/89.17inch

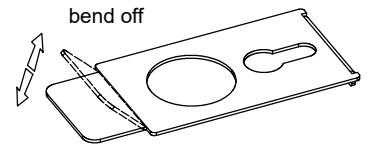

When connection is necessary, please bend off!

CONNECTION

1. Connect the fixture on the back first

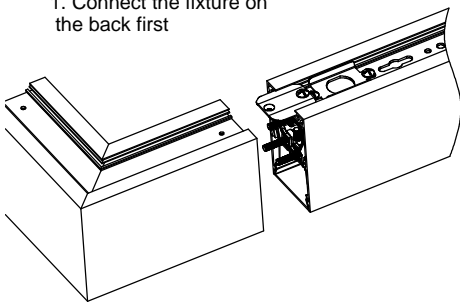

2. Connect the inner cap together

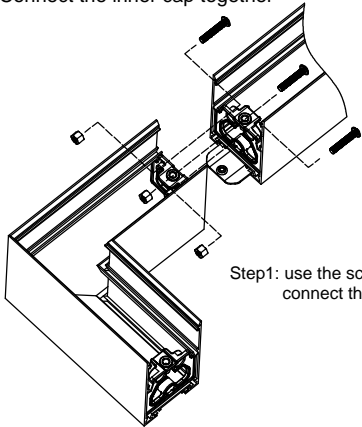

Step1: use the screw 3xUNC8-32 connect the inner end c

D)

Note: Keep balance for the connected fixtures

Step 2: take off reflector

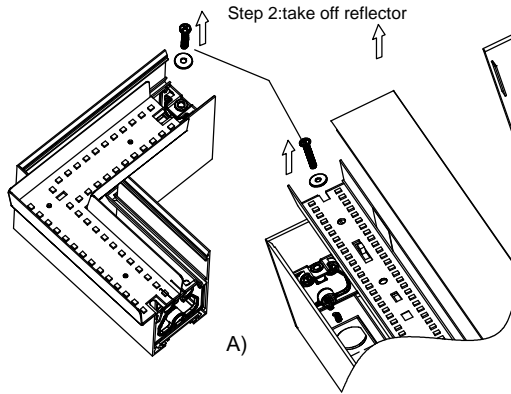

A)

Step 4: Slide in the connection plate

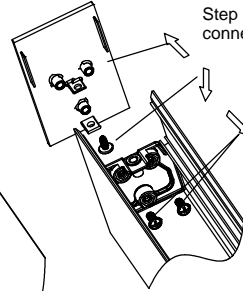

Step 3: take off the end caps

B)

Step 5: Use screw to fix one one end with fixture

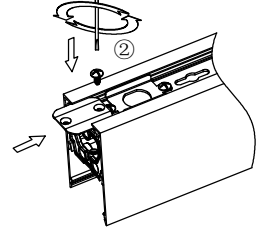

C)

Step 1: take off the lens

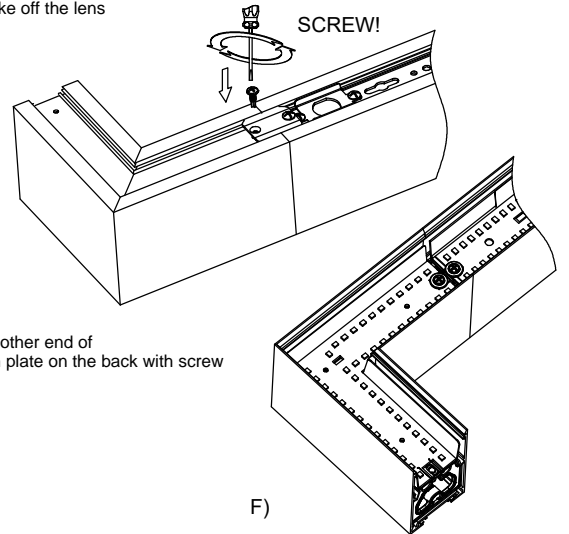

E)

F)

Step2: Fix the other end of the connection plate on the back with screw

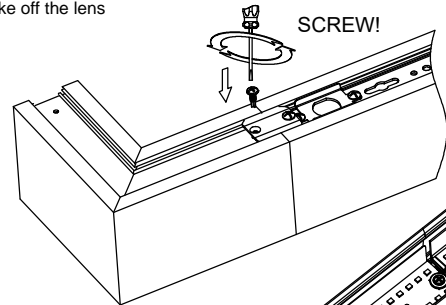

FLANGED RECESSED

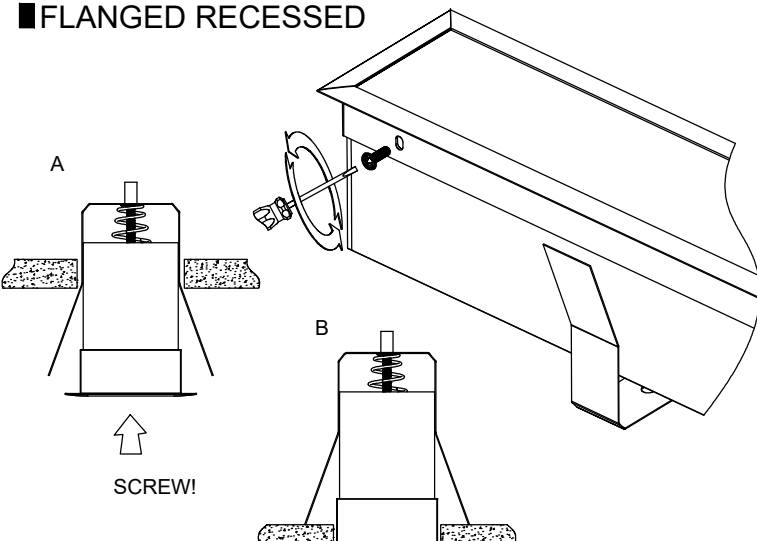

MUD RECESSED

